



---

# TP105R Engine Only Fiche

## Global Regulations 2025

---



# Contents

<b>Section A: Engine.....</b>	<b>3-4</b>
Tillotson TPP-105R Engine.....	3
Sealing.....	3
Material Permitted to Manipulate .....	3
Engine Components.....	3
Exhaust System .....	4
Clutch .....	4
Sparkplugs.....	4
<b>Section B: Carburettor .....</b>	<b>4</b>
<b>Section C: Oil.....</b>	<b>5</b>
<b>Appendix .....</b>	<b>6-11</b>
1. Appx.1 Engine Fiche .....	6-9
2. Appx.2 Carburetor Fiche .....	10-11

## **Section A: Engine**

### 1. Tillotson TPP105R-T4-BAMBINO-PKG-01 Engine:

- 1.1 The engine must remain as original from factory.
- 1.2 No after-market parts are permitted unless stated in TPP-105R engine fiche document.
- 1.3 No machining or other modification of interior engine surfaces (deburring, honing, grinding, polishing, sanding, media blasting and heat treatment) is permitted.
- 1.4 All parts are subject to visual comparison and must remain in substantially unaltered form when compared to an original part.
- 1.5 Engine and all components must comply with engine fiche document.

### 2. Sealing:

- 2.1 TPP-105R engines must be fitted with the original engine ID Seal correlating with the engine ID number as supplied from the Tillotson factory. If an alternative seal number is identified the engine is not valid for competition.
- 2.2 Tillotson is the only sealing agent permitted to open the engines and re-seal as necessary.

### 3. Material Permitted to Manipulate:

The following areas of adjustment and cleaning are permitted within reason. Any effect that alters the integrity of the components or which in the sole opinion of the scrutineer extends beyond reasonable cleaning is prohibited.

- 3.1 Valve clearances may be adjusted, and valves may be cleaned; however, valves must remain with the factory specification of 45-degree angle only. Valve seats of additional angles and/or angles not comparable to the factory stock of 30-45-60 degrees are not permitted.
- 3.2 Spark plugs may be cleaned to remove carbon.
- 3.3 The piston and combustion chamber may be cleaned to remove carbon.
- 3.4 Damaged thread repair: It is permitted to use Heli-coil or a similar thread repair insert as long as the part, after repair, is within the dimension, weight or measurements set on the engine fiche document.

### 4. Engine Components:

- 4.1 Engine ignition switch and wires must remain in original location. It is not permitted to alter the wiring.
- 4.2 It is mandatory to use the original Air filter assembly, P/N 306102054. No modification to the filter element is permitted.
- 4.3 A protective shield may be attached for wet-weather competition. It is not permitted for the protective shield to create any ram-air effect.
- 4.4 The rain shield is only permitted to be used when the track is declared wet or open. It is not permitted to be used when the track is declared as a dry race.
- 4.5 Pulse signal from the engine must be taken from the carburettor pulse connector to the fuel pump connection.
- 4.6 Only original Fuel Pump is permitted. P/N: FP-10A
- 4.7 It is mandatory to use the clutch guard as supplied on all Left-Hand drive go-karts (T-CLU-GRD-01). It is mandatory to use clutch guard RLV PN: ETT0491 on all Right-Hand drive go-kart in an unaltered configuration. A minimum of two bolts must be used to mount the

supplied chain guard.

- 4.8 A maximum of one in-line fuel filter is mandatory to ensure that dirt and contamination within the fuel system does not affect engine performance. We recommend the supplied FS-1P.
- 4.9 Blower housing / starter assembly must be original and properly installed. No taping, covering, or restricting of air of any part of this assembly is permitted.
- 4.10 No aftermarket kill switch may be allowed and the OEM kill switch must be as supplied by manufacture.

## 5. Exhaust System:

- 5.1 The Exhaust System is mandatory as supplied by Tillotson with the engine.
- 5.2 Exhaust System comprises of the following P/N's: 306102057, 306102058, 306102060.
- 5.3 All parts must remain as originally supplied. No tuning, modification or manipulating of material is permitted.
- 5.4 The Exhaust gasket must remain intact as originally supplied.
- 5.5 Exhaust gasket must be original, one and only one piece may be used. Use of silicone is permitted.
- 5.6 Use of an O2, EGT or CO2 sensor is NOT permitted.

## 6. Clutch:

- 6.1 The following clutch is the only permitted clutch.
  - P/N: T-CLU-NS-18T-BB01
- 6.2 The clutch must be original as supplied by the manufacturer and no tuning, modification or manipulating of material is permitted.
- 6.3 It is strongly advised to mount the clutch inboard to avoid added strain on the crankshaft.

## 7. Spark Plugs:

- 7.1 The original spark plug supplied with the engine – Autolite 255 is mandatory to use P/N 306102022.
- 7.2 Sealing washer must be in place and remain original on the stock spark plug used.
- 7.3 Temperature thermocouple is permitted with an unaltered sealing washer in place.

***During technical inspections, a new stock part can be used as reference to compare a competitor's part for legality.***

## **Section B: Carburettor**

### 1. Tillotson FM10-1A Carburettor:

- 1.1 The carburettor must remain as originally supplied from Tillotson.
- 1.2 No after-market parts are permitted.
- 1.3 No machining or other modification of the surface finish is permitted.
- 1.4 Only the Tillotson supplied jets and slides are permitted for use.
- 1.5 All parts are subject to visual comparison and must remain in substantially unaltered form when compared with an original part.
- 1.6 Carburettor and all components must comply with carburettor fiche.

**Section C: Oil**

1. Tillotson Racing Xeramic Oil: P/N: T-OIL-001
  - 1.1. Tillotson Racing Xeramic Oil is the only oil permitted for use in the TPP-105R engine.
  - 1.2. Minimum volume of oil to be filled is 350ml. On technical inspection a minimum quantity of 300ml of Oil must be present in each engine if drained.
  - 1.3. No oil additives or foreign substances are permitted to use along with the oil.
  - 1.4. Xeramic have developed with Tillotson a DYE test which can be carried out during technical inspection on race day.
  - 1.5. Failure of the DYE test will result in exclusion and/or other penalties issued by the event organisers.

***Refusal to adhere to any of the rules set out will be investigated by the race officials and may result in disqualification from the race results***

## Tillotson TPP-105R Engine Fiche T4 Series Global Rules 2025





FEATURE	SPECIFICATIONS
Engine Type	2 Valve 4-Stroke
Fuel Type	Unleaded Petrol
Cylinder	Single Aluminum Block w/Cast Iron Sleeve
Cylinder Volume	105cc
Bore	54mm
Stroke	46mm
Cooling System	Air
Carburetor	Tillotson FM10-1A
Cylinder Head	Aluminum Alloy 2-Valve Over Head Valve
Compression Ratio	8.6 : 01
Rod Length	76mm
Engine Oil	Tillotson T4 Racing Oil, 350 ml ± 50 ml



Engines must conform to the technical data provided with no modification or machining allowed. Parts must be original as supplied by the manufacturer







Cylinder Head PN 306102021		
<b>A.</b>	Overall Height	52mm min
<b>B.</b>	Intake Seat ID	19.06mm ± 0.2mm
<b>C.</b>	Exhaust Seat ID	16.83mm ± 0.2mm
<b>D.</b>	Intake Port Max Height	18.09mm ± 0.2mm
<b>E.</b>	Intake Port Max Width	18.09mm ± 0.2mm
<b>F.</b>	Exhaust Port Max Height	18.15mm ± .02mm
<b>G.</b>	Exhaust Port Max Width	18.15mm ± .02mm

			
<b>Cylinder Head Gasket PN 306102024</b>		<b>Rocker Arm PN 306102037</b>	
Material	Composite	Material	Steel
Thickness	1.26 mm ± .3 mm		

					
<b>Valve Lifter/Tappet PN: 306102040</b>		<b>Valve Spring PN: 138190087</b>		<b>Push Rod PN: 306102039</b>	
Overall Length	33mm ± 0.2 mm	Material	Steel	Material	Steel
Stem Diameter	6mm ± 0.2 mm	Diameter	1.62mm ± 0.25mm	Overall Length	115 mm ± 0.25 mm
Head Diameter	19.7mm ± 0.2 mm	Overall O.D.	15.8 mm ± 0.2 mm	Rod Diameter	4 mm ± 0.2 mm
Weight	12.5g +/- 0.5g	Weight	3.0g ± 0.3g	Weight	11g min

					
<b>Intake Valve PN: 306102044</b>		<b>Sparkplug</b>		<b>Exhaust Valve PN: 306102043</b>	
Material	Alloy Steel	Model	255	Material	Alloy Steel
Overall Length	42mm min	Brand	Autolite	Length	42mm min
Stem Diameter	5.3mm min			Stem Diameter	5.3mm min
Head Diameter	19.05mm max			Head Diameter	21.15mm max
Weight	12.5g min			Weight	14g min

					
<b>Ignition Coil PN: 306102069</b>		<b>Clutch PN T-CLU-NS-18T-BB01</b>		<b>Exhaust PN 306102058</b>	
RPM Limit	No Limit	Brand	Noram Stinger	Overall Length	126.2mm
Type	Analog TCI	Weight	1.245kg (with keyway)	Overall Width	78.2mm
		Clutch Shoes	3pcs	Exhaust Outlet	17mm
		Clutch Springs	3pcs	Weight	242g

			
<b>Exhaust Gasket PN 306102060</b>		<b>Right Hand Drive Chain Guard RLV PN ETT0491</b>	
Thickness	3.84mm	General Dimensions	~7.50" High X ~6.50" W X ~2.75" Deep
Centre Hole Diameter	18.16mm		

<b>Fastener Torque Specs</b>		
<b>Description</b>	<b>Wrench/ Socket Size</b>	<b>Torque</b>
Blower Housing	8 mm	10 N.m
Carburetor to Manifold	10 mm	10 N.m
Connecting Rod	1/4" 12 Point	13 N.m
Cylinder Head Bolts	12 mm	20 N.m
Exhaust Brace Screw	13 mm	24 N.m
Exhaust Stud	8 mm	10 N.m
Flywheel Fan	21 mm	40 N.m
Intake to Cylinder Head	5 mm	10 N.m
Oil Drain Plug	10 mm	20 N.m
Rocker Arm Stud	12 mm	24 N.m
Rocker Arm Set Screw	10 mm	10 N.m
Sparkplug	21 mm	24 N.m
Side Cover	10 mm	18 N.m
Valve Cover	8 mm	7 N.m

APPENDIX 2  
Carburetor Fiche

**CARBURETOR  
TILLOTSON FM10-1A**



Manufacturer	TILLOTSON LTD.
Make	TILLOTSON
Model	FM10-1A

**Measurements & Tolerance Index**

ITEM	DESCRIPTION	TOLERANCE	METRIC
1	Venturi Max Measurement	0.421" Max	10.7mm Max
2	Throttle Bore Diameter	0.594" Max	15.1mm Max
3	Air Jet for Idle	0.048 +/- 0.004"	1.22 +/- 0.1mm
4	Air Jet for Main Jet	0.033 +/- 0.004"	0.85mm +/- 0.1mm
5	Emulsion Tube Drilling Dia. (x 16)	0.024" Max	0.62mm Max
6	Emulsion Tube Drilling Dia. Top (x 2)	0.029" Max	0.75mm Max
7	Emulsion Tube Dia. at Top	0.061" Max	1.55mm Max
8	Emulsion Tube Dia. at Bottom through centre	0.067" Max	1.7mm Max
9	Emulsion Tube Length	1.063 +/- 0.006"	27.02mm +/- 0.15mm
10	Main Jet Orifice	0.019" +/- 0.002"	0.5mm +/- 0.05mm
11	Inlet Seat Diameter	0.051 +/- 0.004"	1.3mm +/- 0.1mm
N/A	Float Weight (W/O Needle attached)	0.141 +/- 0.017Oz	4g +/- 0.5g
N/A	Feedhole for Air Jet (under plastic cover)	0.087 +/- 0.004"	2.23mm +/- 0.1mm
12	Butterfly Diameter	0.59 +/- 0.004"	15mm +/- 0.1mm
N/A	Butterfly Thickness	0.039 +/- 0.004"	1mm +/- 0.05mm
13	Insulation Block Diameter	0.7 +/- 0.004"	17.76mm +/- 0.1mm
N/A	Insulation Block Thickness	0.226 +/- 0.004"	5.76mm +/- 0.1mm

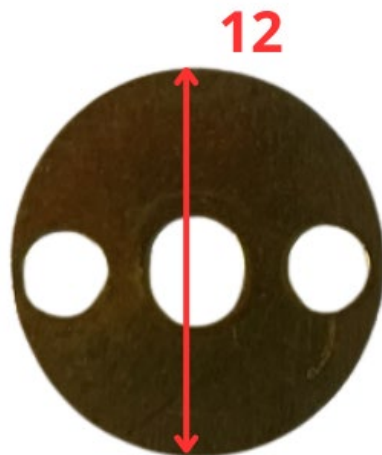
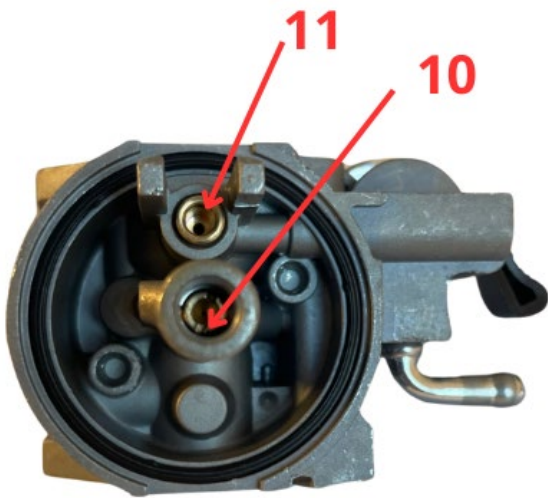
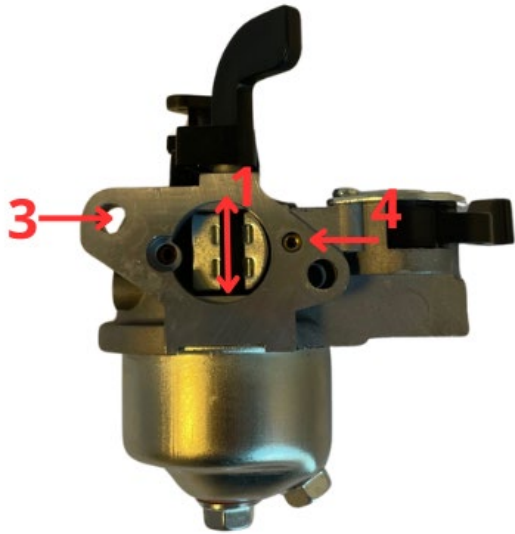

## Contact Information and Resources

Email: [sales@tillotson.ie](mailto:sales@tillotson.ie)

Website: [www.tillotson.ie](http://www.tillotson.ie)

Instagram: [https://www.instagram.com/tillotson\\_racing](https://www.instagram.com/tillotson_racing)

Facebook: <https://www.facebook.com/tillotsonracing>

Youtube: [Tillotson Racing - YouTube](#)

